

HIGH FREQUENCY DEVICES

COAXIAL CONNECTORS

SMT, MICROMINIATURE

NEW

GSC Series



FEATURES

- High engagement with new structure (50% up compared with ESC type)
- Ultra-miniature (LxWxH: 3.4x3.4x1.5mm) for high density mounting (11.6mm²)
- Ultra-low profile (3.0mm max.)
- SMD and reflow soldering applicable
- Taping package applicable
- Mountable by automatic placer
- High performance (VSWR: 1.2 max. at 3GHz)
- Matched with ultra-thin FEP coaxial cables (0.8mm dia.)

APPLICATIONS

Portable, mobile and cordless telephone, GPS, and other microwave radio and measurement equipment

PART NUMBERING – RECEPTACLE

Part Number	Packaging	Quantity
MM9329-2700	Bulk package	Specify
MM9329-2700TB1	178mm Dia. Taping	1000pcs/reel
MM9329-2700TB2	330mm Dia. Taping	5000pcs/reel

PART NUMBERING – CABLE ASSEMBLY



- ① Cable assembly
- ② ④ Connector code for each end of cable

Code	Connector
TK	GSC type Plug connector for 92 cable
XX	No connector

- ③ Cable code

Code	Cable	Outer Diameter	Outer Conductor Construction	Minimum Bending Radius	Insulation Material
92	0.4D	0.8mm	Single shield	4.8mm	PFA

- ⑤ ⑥ Full length of cable assembly
Length L (mm) = ⑤ × 10^⑥
Ex. 500mm = 500 × 10⁰ = 5000
1000mm = 100 × 10¹ = 1001

SPECIFICATIONS

Item	Rating and Characteristics
Frequency	From DC to 6GHz
VSWR	1.2 max. (DC ~ 3GHz); 1.3 max. (3 ~ 6GHz)
Nominal Impedance	50Ω
Temperature Range	-40°C to +90°C
Voltage	250Vrms
Contact Resistance	15mΩ max.
Withstand Voltage	300(AC) rms
Insulation Resistance	500MΩ min.
Mating Cycles	100 cycles

DIMENSIONS (MM9329-2700): mm

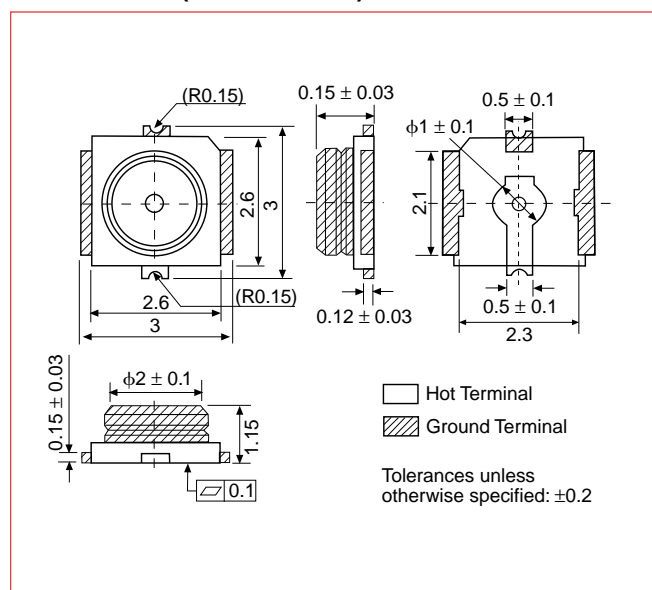

DIMENSIONS (MXTK92□□□□□□): mm

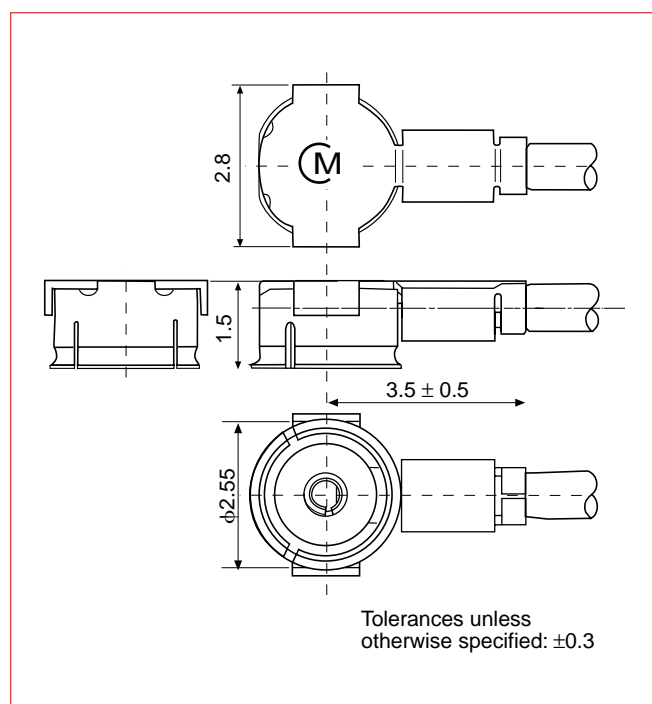

HIGH FREQUENCY DEVICES

MATERIALS AND FINISH MM9329-2700 – RECEPTACLE

Part Name	Materials	Finish
Center Contact	Stainless Steel	Gold plated
Outer Contact	Copper Alloy	Silver plated
Insulator	Engineering Plastic	None

MXTK92□□□□□□ – CONNECTOR

Part Name	Materials	Finish
Center Contact	Copper Alloy	Gold plated
Outer Contact	Copper Alloy	Gold plated
Insulator	Engineering Plastic	None

CABLE LENGTH TOLERANCE

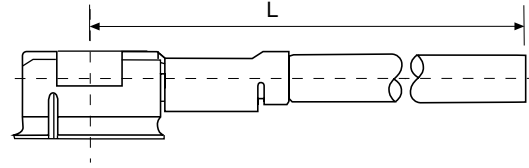

Cable Length L (mm)*		Dimensional Tolerance (mm)
From	To	
40	100	± 3
100	500	± 4
500	1000	±10
1000	—	+2% of L -0% of L

*L must be 20mm min.

TAPE DIMENSIONS: mm

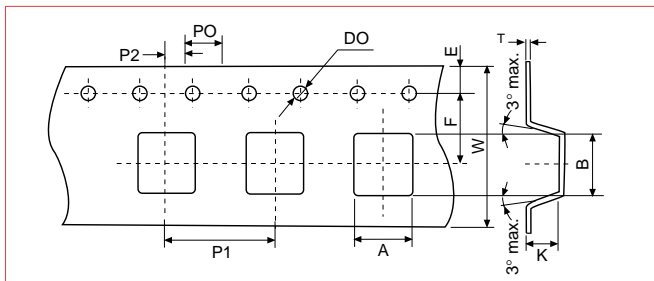

A	B	W	D0	E	F
3.8 ± 0.1	3.8 ± 0.1	12 ± 0.2	φ1.5 ^{+0.1} ₋₀	1.75 ± 0.1	5.5 ± 0.1
K	P0	P1	P2	T	
0.15 ± 0.125	4 ± 0.1	8 ± 0.1	2 ± 0.1	0.3 ± 0.05	

REEL DIMENSIONS: mm

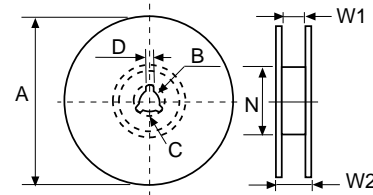

Part No.	A ± 2	B ± 0.5	C ± 0.8	D ± 0.5	N min.	W1 ± 1.5	W2 min.
MM9329-2700TB1	φ178	φ13	φ21	2	φ50	13.5	18.5
MM9329-2700TB2	φ330	φ13	φ21	2	φ50	13.5	18.5

RECOMMENDED MOUNTING DIMENSIONS: mm

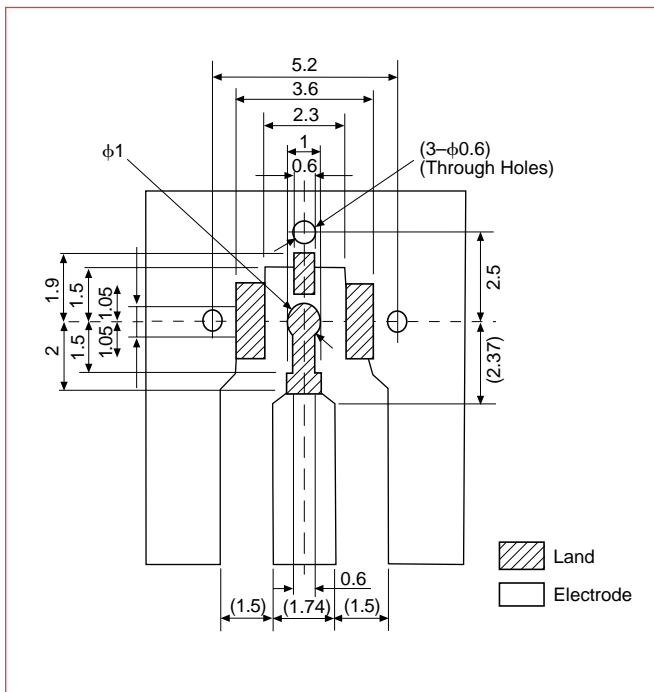

DIMENSIONS: mm

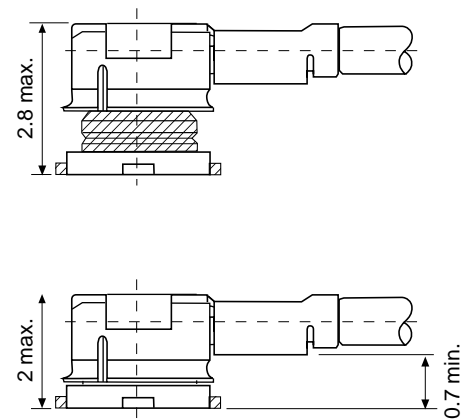

APPLICATION NOTES

- PCB mounting pattern dimensions: Dimensions shown on page 323 "Recommended Mounting Dimensions" should be used for PCB design.
- Disengagement and engagement: Use tool P/N M22001. The connector to be disengaged and engaged should be pulled out or insert to the vertical direction using the tool. Do not try and pull out the cable by hand or wire breakage may result.

- Cable and connector handling: Do not apply a twisting torque to the cable and connector.
- REFLOW SOLDERING CONDITION: Reflow soldering should be carried out according to condition shown in Fig. 3.

DISENGAGEMENT TOOL (Fig. 1): mm

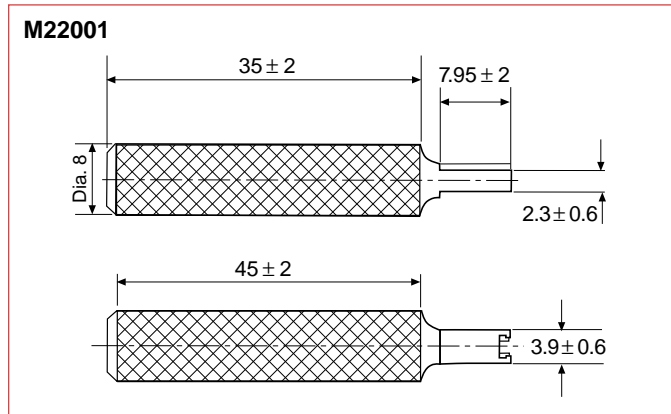

How to use disengagement tool

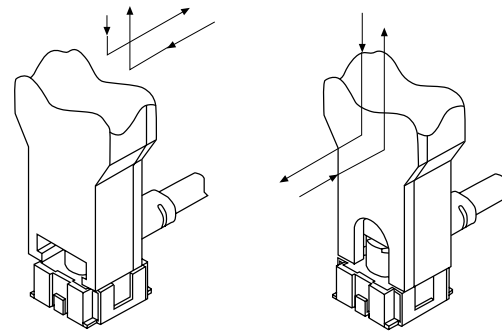

SMA-GSC ADAPTERS (Fig. 2): mm

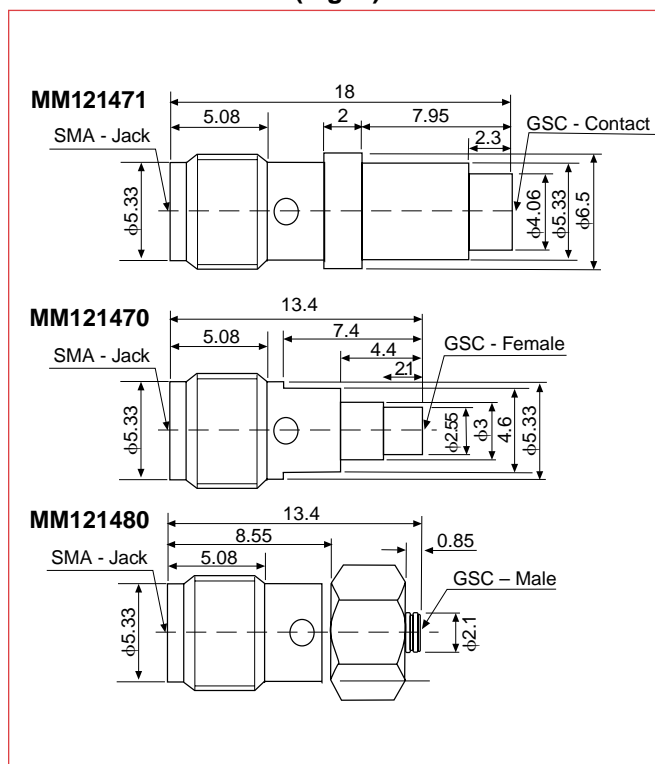

STANDARD REFLOW SOLDERING CONDITIONS (Fig. 3)

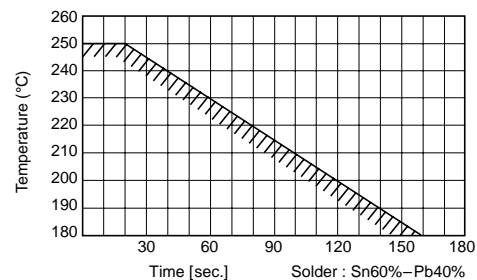

Allowable temperature and time of reflow soldering

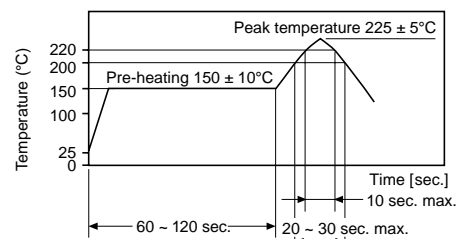

- Measuring point of temperature in-out terminals of the device.
- Reflow Soldering
- Both convection and infrared rays
- Hot air
- Hot plate